

One Source

# Airslide® conveying technology

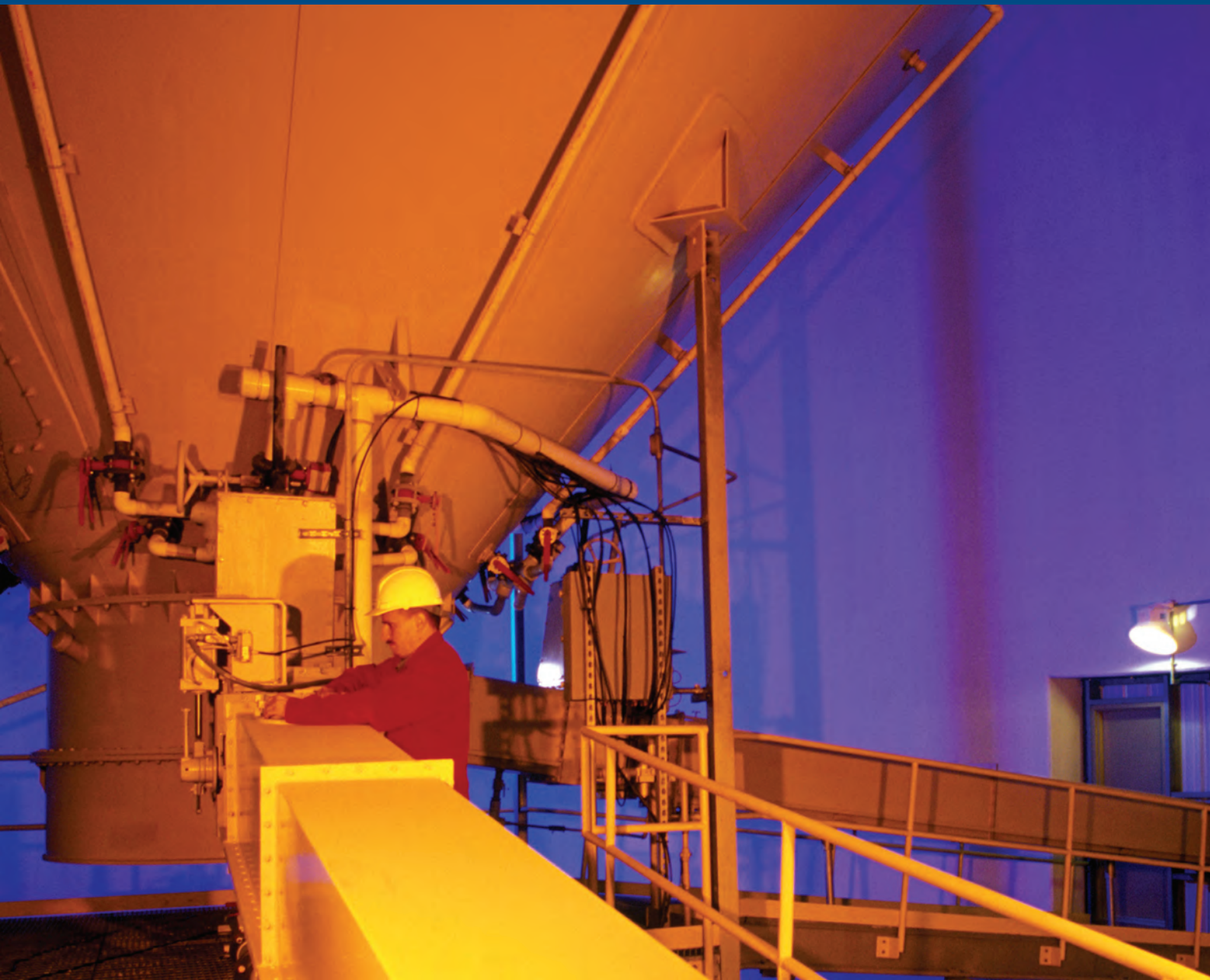

# The Free Power of gravity

- **Low energy requirements - gravity does most of the work**
- **High-capacity material handling**
- **Frees up valuable floor space**
- **Environmentally-friendly**
- **Low noise**

Developed from Fuller® design\* and technology, FLSmidth's Airslide® air gravity conveying system uses the forces of gravity to do most of the work with no moving parts. Material is fluidized through a porous media with low pressure air. Material flow is achieved by sloping the Airslide conveyor to match the fluidized angle of repose of the powdered material. At the correct slope, fluidized materials flow with the consistency of a liquid.

Airslide air gravity systems provide high-capacity material handling while offering many economical and environmental advantages. Energy requirements are minimal because only a small volume of air at a low pressure is required to move material. Since the system is installed overhead, valuable floor space and added headroom are available for other purposes. By eliminating the need for massive support members, it permits a flexibility of plant design not available with straight-line conveyors.

\* Developed by Fuller Company in 1945 in cooperation with Huron Portland Cement.

The Airslide conveyor is dust tight. As a result, the system is extremely friendly to the environment.

Noise level is extremely low in the area surrounding the Airslide conveyor as the system's air supply is the only moving part to generate noise, and it is generally located in a remotely insulated area to further reduce noise. Maintenance of the Airslide conveyor is very simple because there are no moving parts other than the air supply equipment, which also contributes to increased plant safety. Airslide conveyors require no lubrication.

## Typical Airslide conveyor applications

- Distribution from bucket elevators to storage silos
- Gathering under baghouses / precipitators
- Feed to process
- Feed to other conveyors
- Loadout from bulk silos to trucks, railcars or barges
- In-plant conveying
- Storage silo / bin withdrawal

## The Principle of Fluidization:

Driving low-pressure, low-velocity air through and between particles of a dry bulk material, changing its behavior characteristics and making it flow more like a liquid than a solid



All dry bulk material has a natural angle of repose, often in excess of 45°.

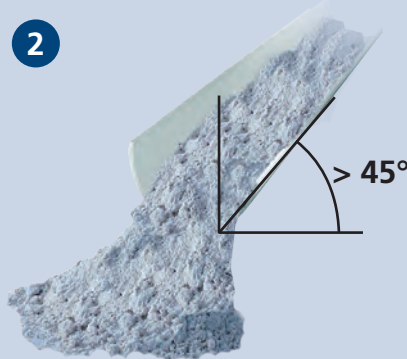

Without any fluidization, the Airslide® conveyor would need to be inclined on an angle greater than the angle of repose to establish gravity flow.

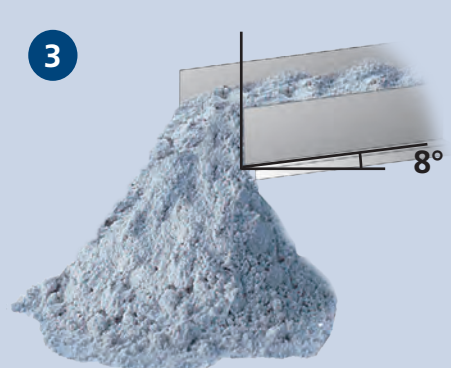

With fluidization, gravity flow can be achieved at a greatly reduced slope - of 8° or less.

# Airslide® conveying applications

## Airslide conveying: quiet & simple point-to-point transfer

- Positive flow regulation (low - high capacities)
- Quiet operation
- Low maintenance — no rotating parts in contact with materials being conveyed
- Fully fluidized gentle conveying action
- Minimized wear from abrasion

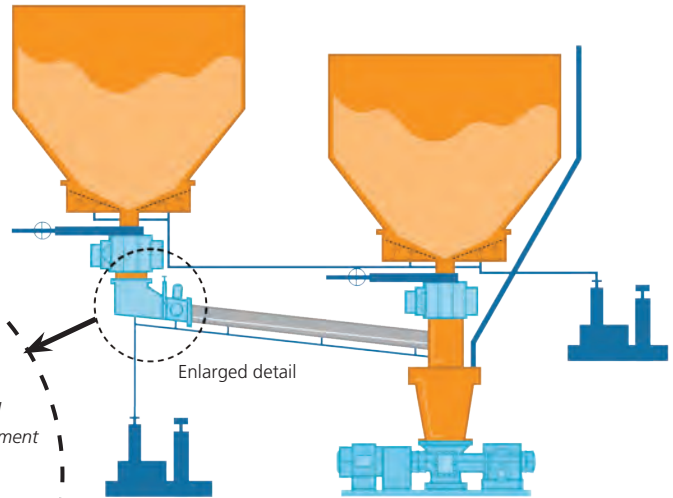
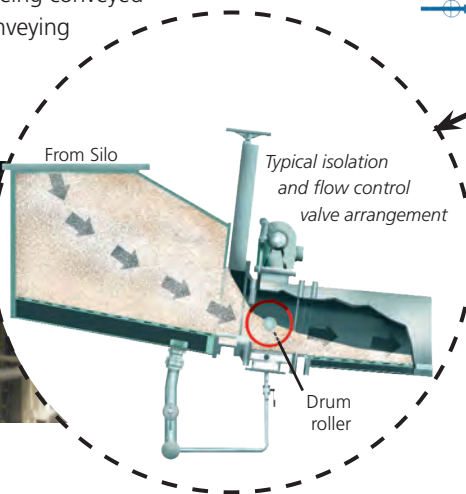

Generally, materials passing through 35 mesh US std. (500 microns) can be conveyed through an Airslide® conveyor

## Airslide loading and unloading systems

### Railcar

- High-capacity loading and unloading

### Trailer

- Dust-controlled loading and unloading

### Large Diameter Silos

- Efficient filling and unloading systems
- Uniform filling system
- Fluidized silo bottom

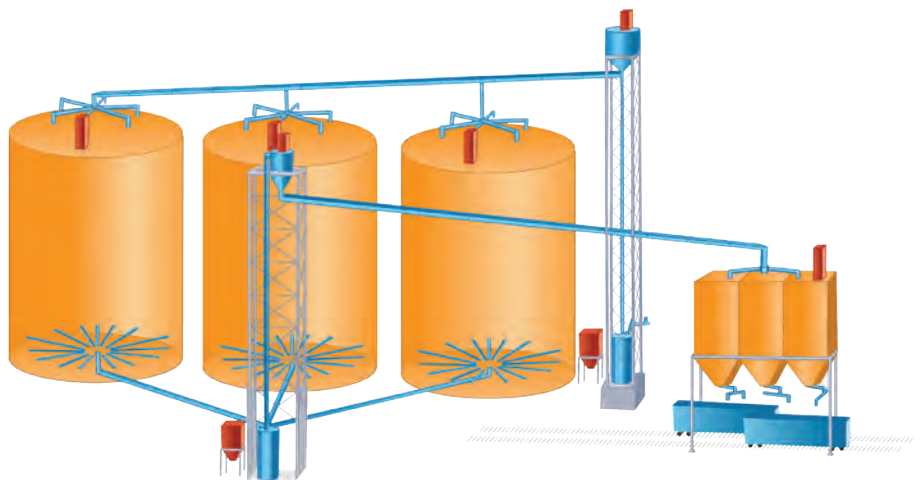

FLSmidth's Airlift™ vertical conveyors and Airslide® gravity conveying systems convey alumina at a net rate of 750 mtp in a major western United States facility



# Typical Airslide® conveying system

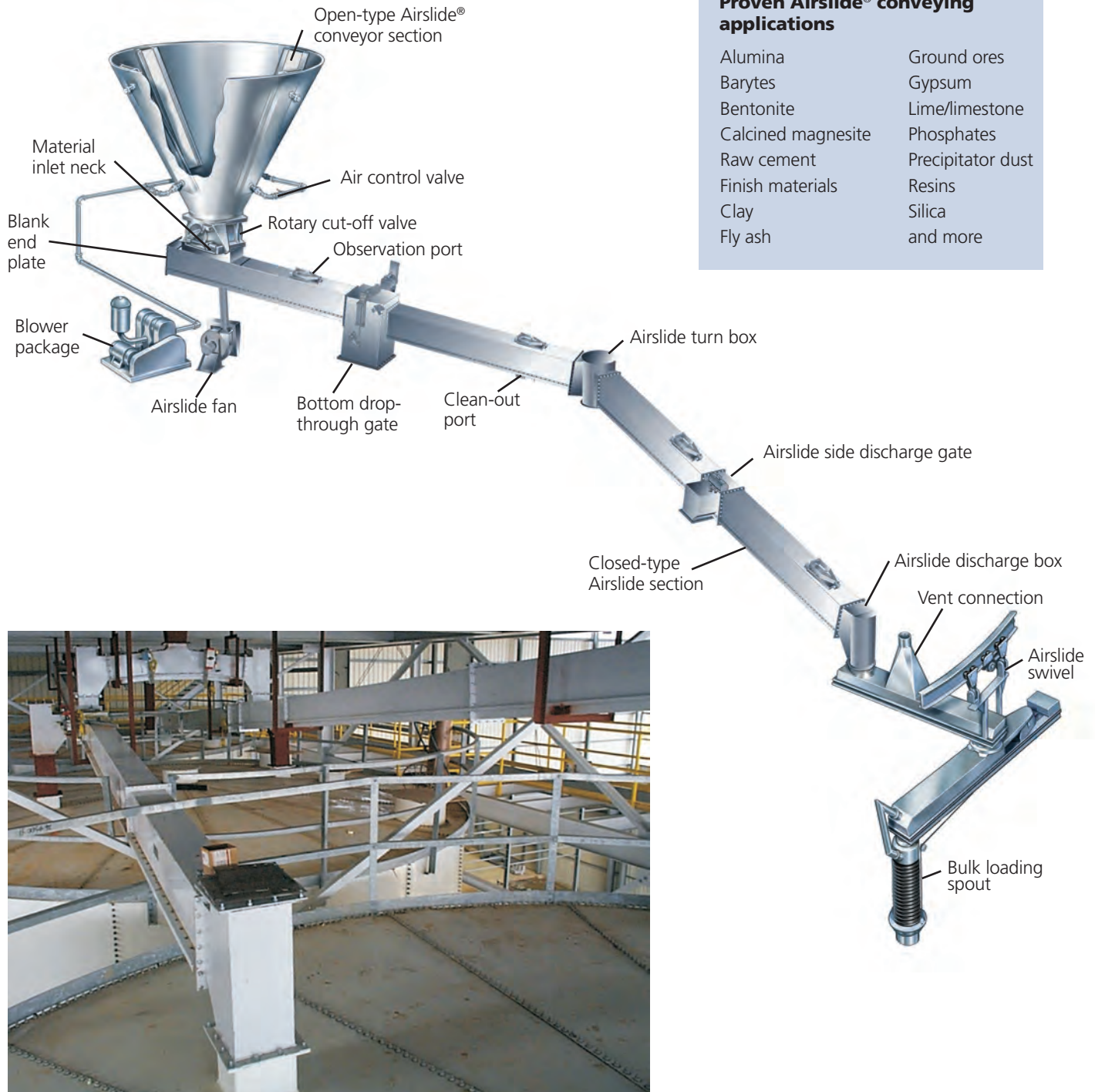

## Proven Airslide® conveying applications

Alumina	Ground ores
Barytes	Gypsum
Bentonite	Lime/limestone
Calcined magnesite	Phosphates
Raw cement	Precipitator dust
Finish materials	Resins
Clay	Silica
Fly ash	and more

The Airslide® air activated gravity conveying equipment can provide a design flexibility with many accessories and flow control devices to meet the needs of the any specific application.

# Designed for dependability. Proven to perform.

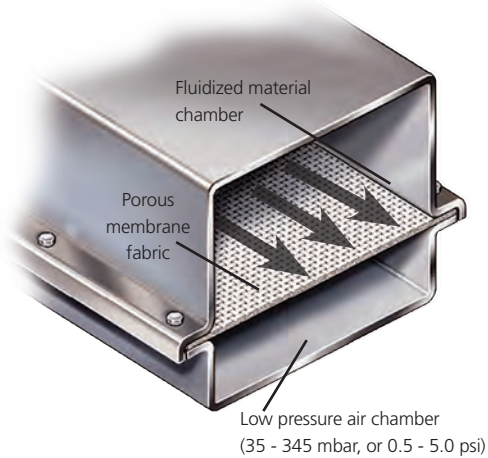

## FLSmidth's Airslide® system operation

- Air-activated gravity conveyor
- Fluidization of material on the Airslide media
- Fluidization reduces the angle of repose causing flow
- Example: A material with a normal angle repose of 45° with fluidization may flow like a liquid on a slope of 8° or less

## Manufacturing standards

- Heavy-gauge steel sections with bent flanges
- Airslide conveyors are shipped in standard section lengths of 3 meters (9.85 feet)
- Standard widths of fluidized area is 100 to 850mm (4 to 34 inches)
- Bolted airtight construction
- Optional media available for high temperature and highly abrasive materials
- There is no conveying length limitation to the Airslide conveyor based upon availability of headroom and proper slope

## Proprietary Airslide fabric

- Proprietary weave designed for air gravity conveyors
- Even permeability over the entire length of fabric
  - Requires only one air connection every 30 meters (100 feet)
  - No "dead" zones

## Airslide conveying multiple inlet to multiple outlets

- Flexibility
  - No additional conveyors needed to change directions
- Single Power Source
  - One blower or fan is sufficient for system
- High Capacity / Long Distance
  - Conveying volumes up to 2,460 cubic meters (87,000 cubic feet) per hour and conveying distances in the 100s of meters/feet

## Airslide® media and dimensions

[www.flsmidth.com](http://www.flsmidth.com)

FLSmidth's Airslide® Conveying Media Options		
Section	Material	Application
F	Woven 5-ply polyester	Standard up to 177°C (350°F)
FN	Needle felt polyester non-woven	Standard non-silo bottom applications up to 177°C (350°F)
KN	Needle kevlar non-woven	Standard non-silo bottom applications up to 246°C (475°F)
K	Woven kevlar	Standard including silo bottom applications up to 246°C (475°F)
GAX 19	Woven fiberglass	High temperature up to 454°C (850°F)

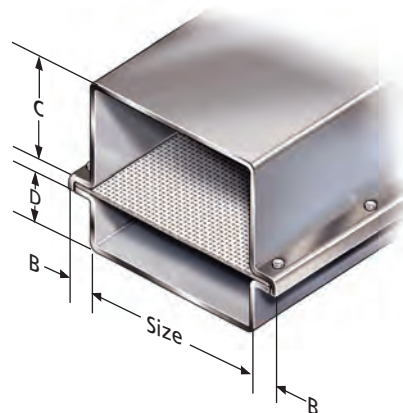

See chart below for dimensions

Standard (Hi-top) Design										
Size	Capacity		B		C		D		Weight	
	mm	cu.m/hr.	mm	(1) in.	mm	(1) in.	mm	(1) in.	kg/m	lb./ft.
100*	20	720	32	1.25	200	7.87	75	2.95	19	13
150*	34	1200	32	1.25	200	7.87	75	2.95	22	15
200	87	3060	32	1.25	300	11.81	75	2.95	36	24
250	165	5830	32	1.25	300	11.81	75	2.95	39	26
300	315	11125	32	1.25	400	15.75	75	2.95	46	31
350	450	15900	32	1.25	500	19.69	75	2.95	55	37
400	630	22250	32	1.25	500	19.69	75	2.95	58	39
480	1080	38140	38	1.50	560	22.05	75	2.95	66	44
600	1585	56000	57	2.25	600	23.62	100	3.94	80	54
850	2460	87000	76	3.00	910	35.83	100	3.94	123	83

Nominal capacity ratings are based upon loose poured bulk density of the material and proper application.

(1) English dimensions and capacities are nominal

\* Only available for special applications. Please contact a Product Specialist to review application.

### Project Center Denmark

FLSmidth A/S  
Vigerslev Allé 77  
DK-2500 Valby  
Copenhagen  
Tel: +45 3618 1000  
Fax: +45 3630 1820  
E-mail: info@flsmidth.com

### Project Center USA

FLSmidth Inc.  
2040 Avenue C  
Bethlehem, PA 18017-2188  
Tel: +1 610-264-6011  
Fax: +1 610-264-6170  
E-mail: info-us@flsmidth.com

### Project Center India

FLSmidth Private Limited  
FLSmidth House  
34, Egatoor, Kelambakkam  
(Rajiv Gandhi Salai, Chennai)  
Tamil Nadu – 603 103  
Tel: +91-44-4748 1000  
Fax: +91-44-2747 0301  
E-mail: indiainfo@flsmidth.com